

NOTES:

1. TORQUE RATINGS, Nm :
SYMMETRIC TORQUE: 0.4-0.9 , CW=CCW
2. CYCLE LIFE:
WITHIN 25,000 CYCLES STATIC TORQUE STAY WITHIN ±20% OF TORQUE SPECIFICATION.
3. FINISH: PLATING
4. 180 DEGREE SHAFT ROTATION
5. SELF LOCKING FEATURE:
WHEN CLOSING TOWARD CCW DIRECTION TO ABOUT 75 DEGREE HINGE SHALL SELF CLOSE TO 90 DEGREE

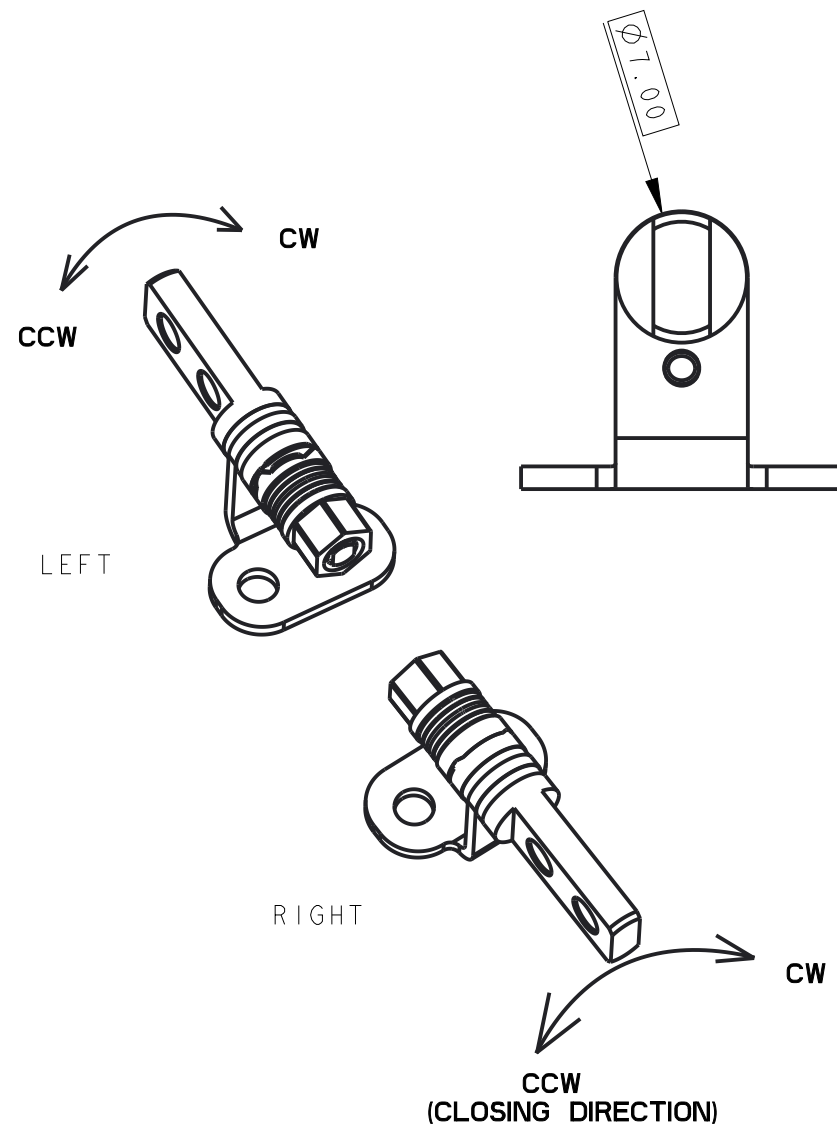

METRIC(MM)	[ENGLISH] (IN)	LEEEO		DWG NO.		
0-3 < ±0.15	0-0.118 < ±0.006			LL7B-1003-xxL/R		
3-10 < ±0.20	0.118-0.394 < ±0.008	APPROVED		DRAWN		TITLE
10-30 < ±0.25	0.394-1.181 < ±0.010					LL7B
30-50 < ±0.30	1.181-2.000 < ±0.012	JLIU		BCHEN		MATERIAL
50-100 < ±0.40	2.000-4.000 < ±0.016					STEEL
100-200 < ±0.50	4.000-8.000 < ±0.020	SHEET 1 OF 1		SCALE: 1.000		REV
PROPRIETY ITEM - ALL INFORMATION DISCLOSED HEREON IS CONFIDENTIAL AND ALL RIGHTS PATENT AND OTHERWISE ARE RESERVED BY LEEEO TECHNOLOGIES CORPORATION				A3		